

# ENGINE--Timing Covers, Fan, Pulley and Fan Belt.

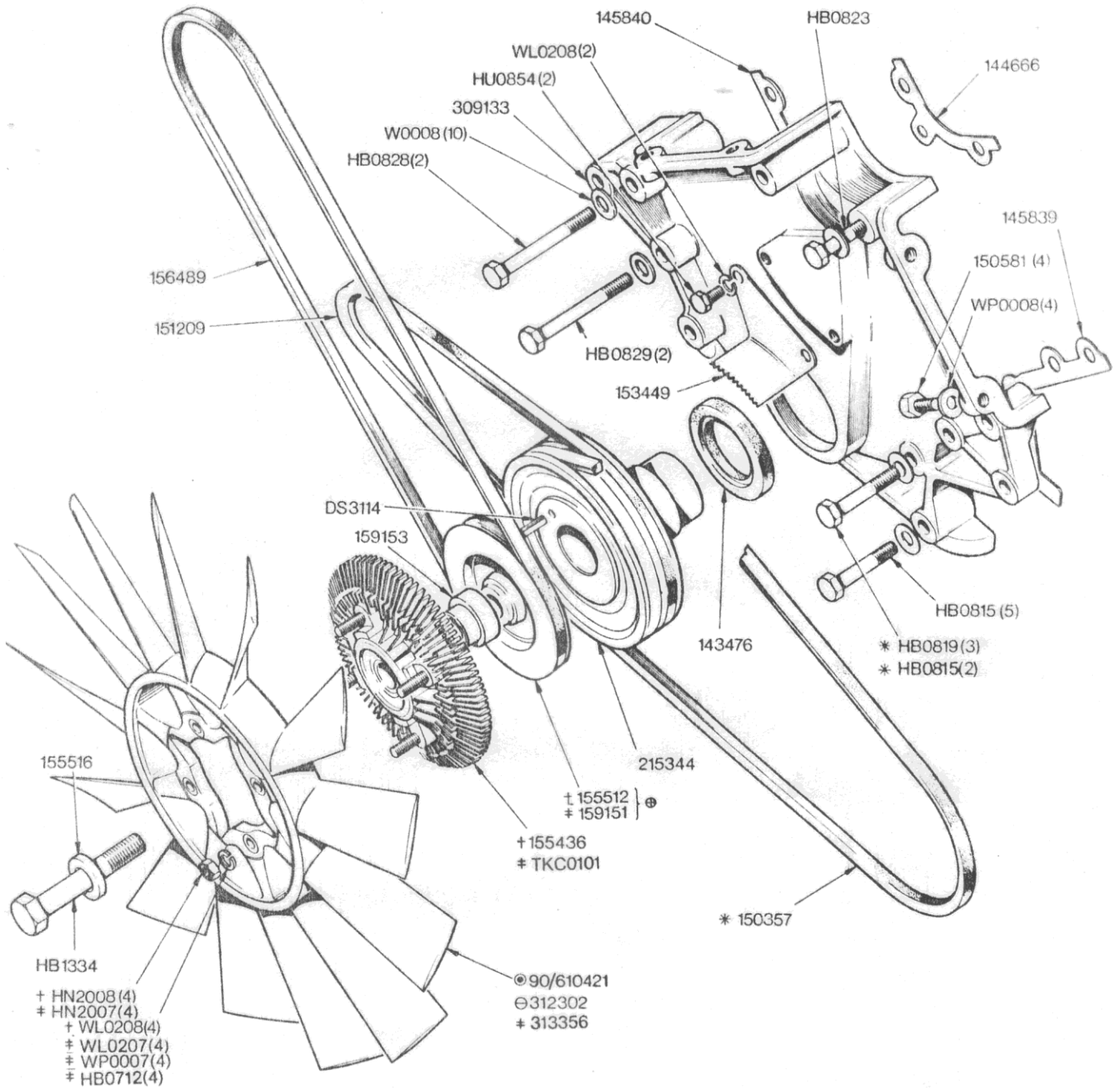

**NOTE**

\* REQUIRED ON AIR CONDITIONING MODELS ONLY

⊕ 155512 May be used on late models using 159153 as a spacer

Note:-The details on this Plate are fitted from Engine No LF1E and future (all markets except USA) and Engine No LE1E upto LE10000E (USA only) for future see plate 02-13

- ⊙ Fitted up to Engine No LE11276U only
- ⊖ Fitted from Engine No LE11276U and future
- † Fitted up to Engine No only
- ‡ Fitted from Engine No and future

# ENGINE

02-12 Timing Covers, Fan, Pulley and Fan Belt	Part No	
	Triumph	Rimmer Bros
Crankshaft front oil seal	143476	
Gasket	144666	144666
Gasket	145839	145839
Gasket	145840	145840
Drive belt - air conditioning	150357	GCB21075
Bolt	150581	
Drive belt - alternator	151209	151209
Timing quadrant	153449	153449
Viscous coupling - to LF23070	155436	155436
Pump pulley - to engine no ?	155512	
Washer - dowel	155516	155516
Drive belt - power assisted steering pump	156489	GFB11113
Pump pulley - from engine no ?	159151	159151
Fan spigot	159153	159153
Crankshaft pulley & TV damper	215344	215344
Timing cover	309133	309133
Cooling fan - from engine no LE11276U	312302	312302
Cooling fan - from engine no?	313356	PKC820
Cooling fan - to engine no LE11276U	90/610421	
Dowel	DS3114	DS3114
Bolt - air conditioning models only	HB0815	HB816
Bolt - non air conditioning models	HB0815	HB816
Bolt - air conditioning models only	HB0819	BH605201
Bolt	HB0823	BH605321
Bolt	HB0828	GHF301
Bolt	HB0829	BH605321
Bolt - pulley retaining	HB1334	HB1333
Nut - from engine no ?	HN2007	GHF200
Nut - to engine no ?	HN2008	GHF201
Setscrew	HU0854	SH505041
Viscous coupling - from LF23071 & USA Exhaust Emission from LE24001 approx	TKC0101	TKC101
Washer - lock	WL0208	GHF332
Washer - plain	WP0008	GHF301